

**NOTE**

THIS IS A TYPICAL CROSSING PLAN. SLIGHT VARIATIONS MAY OCCUR AFTER INSPECTION AND APPROVAL OF LOCATION BY COUNCIL.

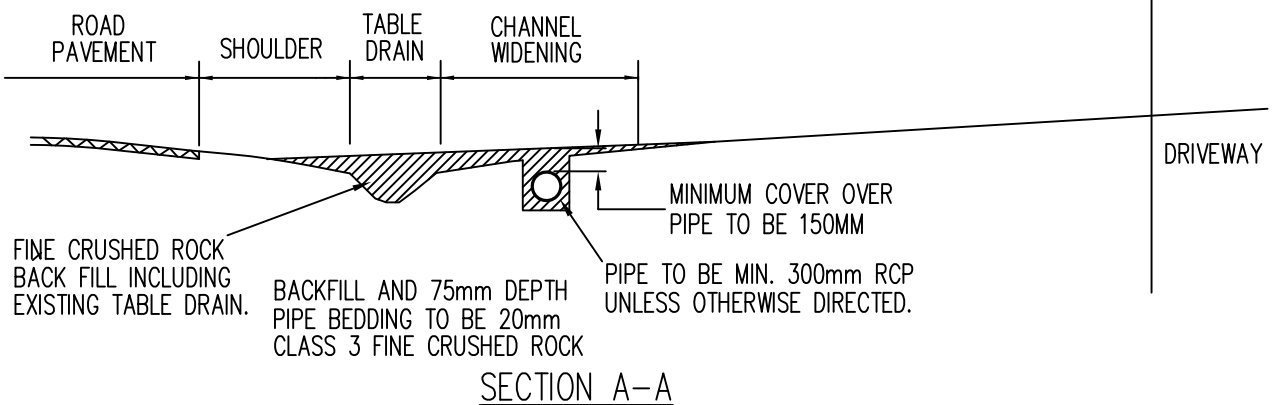
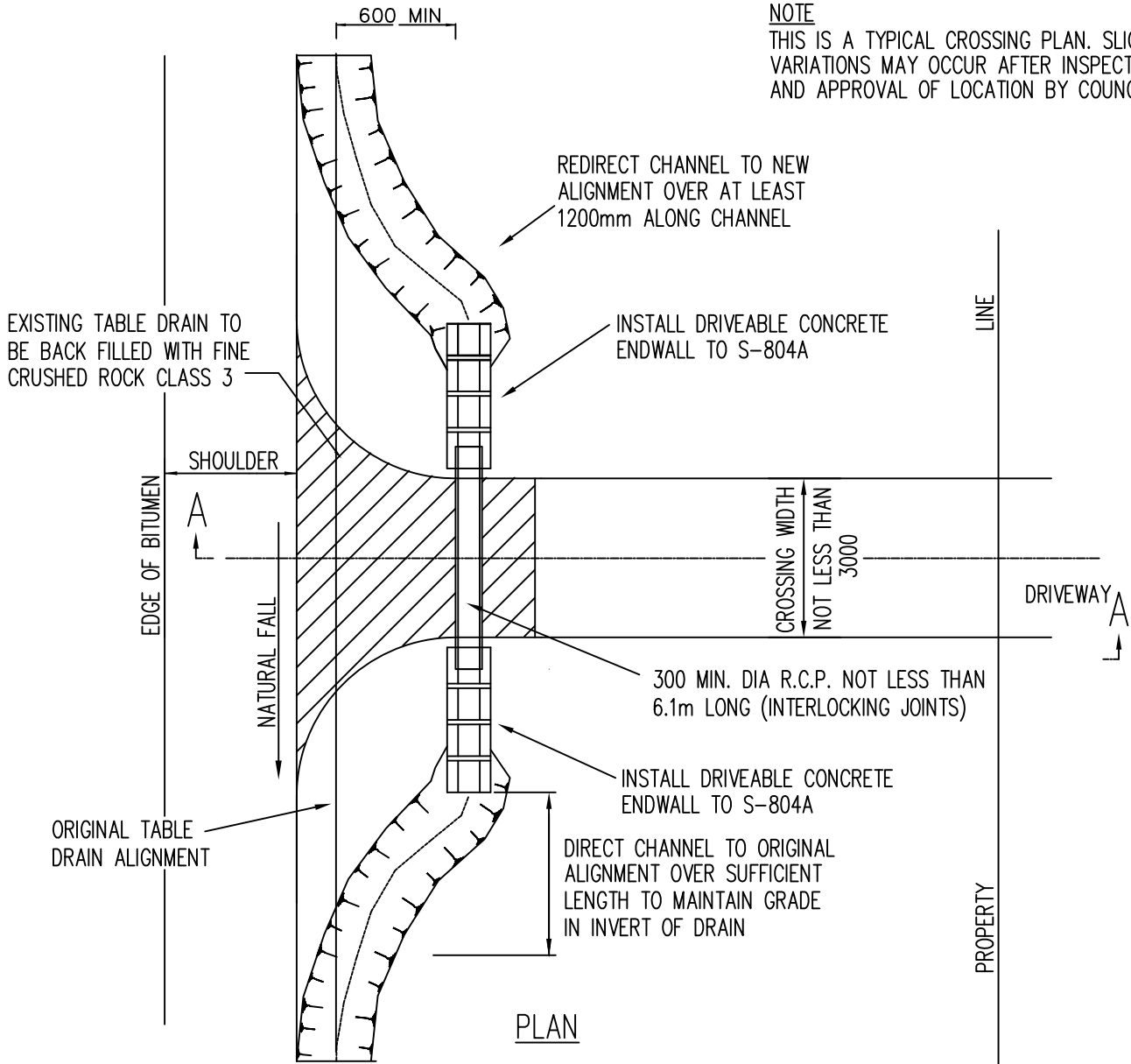

**NOTES**

1. Driveable Endwalls are only required when pipe under crossing occurs within the clear zone as identified in Ausroads 2009 Part 6 Table 4.1

**CITY OF CASEY**

**VEHICLE CROSSING  
OVER TABLE DRAINS**

*Signature*

MANAGER OF ENGINEERING &  
ENVIRONMENTAL SERVICES

LAST UPDATE 09.11.2012

AMENDMENTS: GENERAL UPGRADE

S-804

V2